

FANUC

Kompakten, zmogljiv in popolnoma zaščiten



**UPORABNIŠKI
PRIKLJUČKI**
Integrirani v
robotski roki



ZAPRTA IZVEDBA
Ni izpostavljenih kablov,
motorjev in priključkov



LAHKA IZVEDBA
Nosilnost 35 kg;
Lastna teža 205 kg

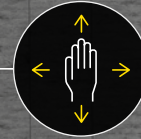

ZMOGLJIVO ZAPESTJE
Kompaktna izvedba
omogoča veliko nosilnost
in vztrajnostni moment



VITKA IZVEDBA ROKE
Omogoča veliko
fleksibilnost

NOVI ROBOT M-20iB/35S

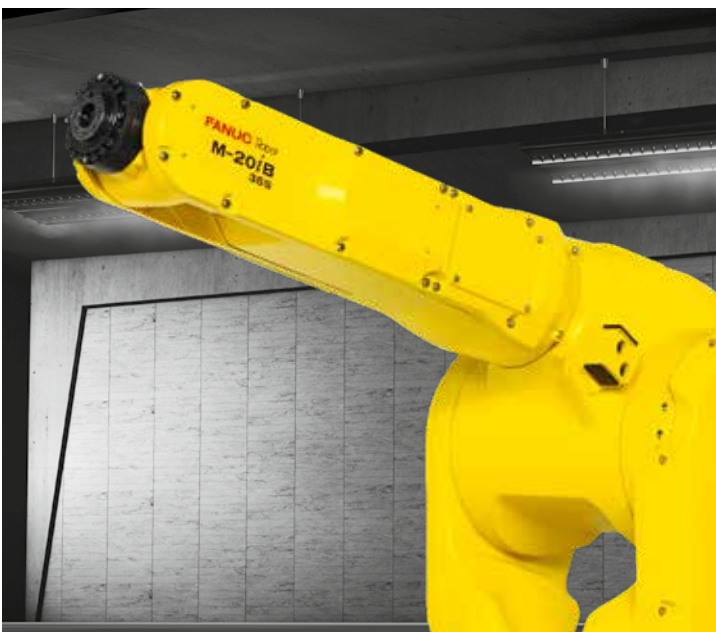

FLEKSIBILNOST NA MAJHNEM PROSTORU

- Najzmogljivejši robot v razredu do 35 kg;
- Kompaktno zapestje v kombinaciji z veliko nosilnostjo in vitko izvedbo robotske roke omogoča gibe z visoko hitrostjo na majhnem prostoru;
- Različne pozicije montaže;
- Najnaprednejša servo tehnologija;
- Zaščita IP 67 za težke obratovalne pogoje.

M-20iB/35S



Max. load capacity at wrist: **35 kg**



Max. reach: **1445 mm**

Controlled axes	Repeatability (mm)	Mechanical weight (kg)	Motion range [°]						Maximum speed [%/s]						J6 Moment/Inertia (Nm/kgm ²)	J5 Moment/Inertia (Nm/kgm ²)	J4 Moment/Inertia (Nm/kgm ²)	J6 Moment/Inertia (Nm/kgm ²)	
			J1	J2	J3	J4	J5	J6	J1	J2	J3	J4	J5	J6					E1
6	± 0.02*	205	340 (360)	240	301,5	400	260	540	-	205	205	260	415	415	880	-	51 / 2.2	51 / 2.2	31 / 1.2

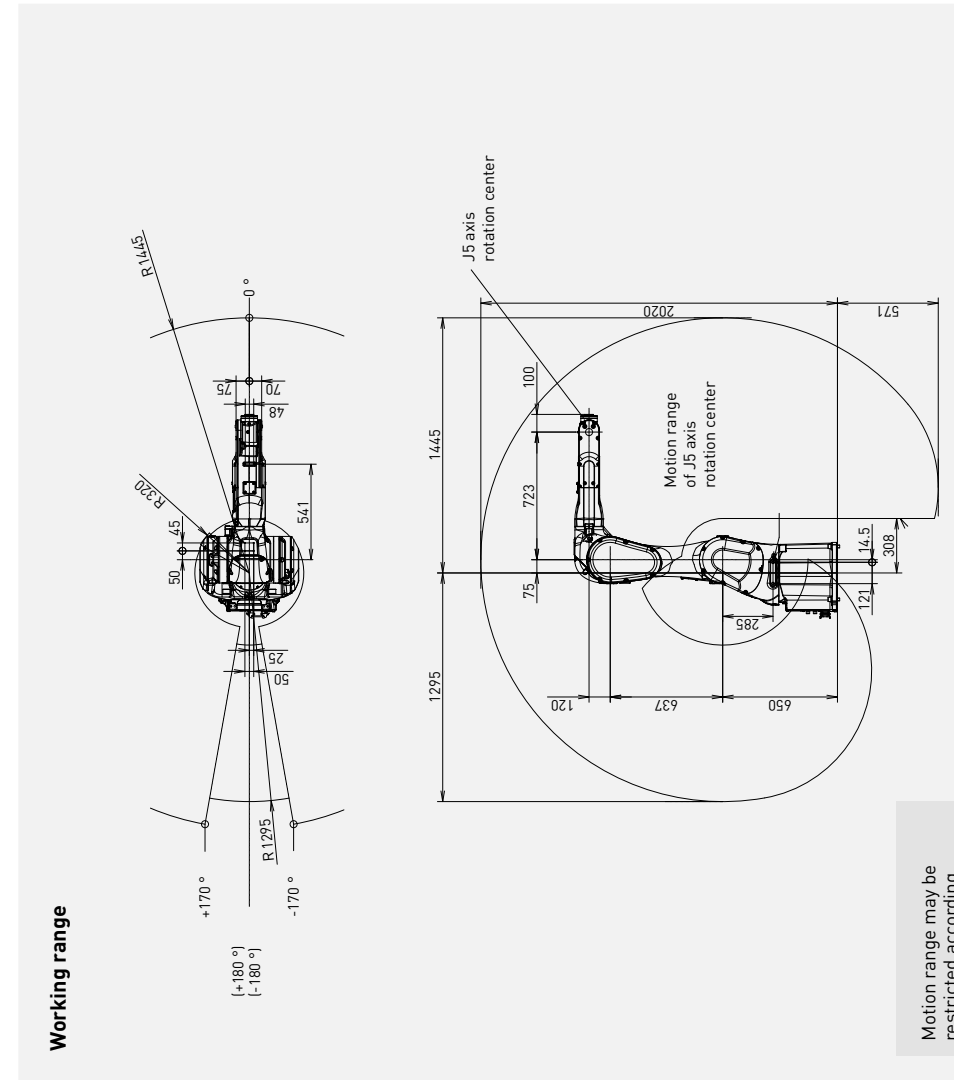

Working range

Motion range may be restricted according to the mounting angle!

Robot

- Robot footprint [mm] **M-20iB/35S**
383 x 343
- Mounting position Floor
- Mounting position Upside down
- Mounting position Angle

Controller

- Open air cabinet
- Mate cabinet
- A-cabinet
- B-cabinet
- iPendant Touch

R-30iB Plus

-
-
-
- o
-

Electrical connections

- Voltage 50/60Hz 3phase [V] 380-575
- Voltage 50/60Hz 1phase [V] -
- Average power consumption [kW] 1

Integrated services

- Integrated signals on upper arm In/Out 8/2
- Integrated air supply 1

Environment

- Acoustic noise level [dB] < 73.2
- Ambient temperature [° C] 0-45

Protection

- Body standard/optional IP67
- Wrist & J3 arm standard/optional IP67

• standard o on request - not available () with hardware and/or software option *Based on ISO9283