

**FANUC**

# NEW M-410iC/110

## Compact, fast and durable



**OPTIMISED KINEMATIC**  
TO ACHIEVE OPTIMAL  
WORKSPACE

**SLIM DESIGN**  
TO REDUCE REQUIRED  
FLOOR SPACE TO MINIMUM

**INTEGRATED SERVICES**  
WITH TOOL INTERFACE  
ON ROBOT HAND



PICTURE SHOWS PROTOTYPE

### Fast, no matter how long the work lasts

- 110 kg payload capacity
- reach 2403mm, max. height 2238mm
- 2200CPH at 60 kg payload (400-2000-400)
- optimised kinematics for efficient palletising
- slim design reduce required floor space to minimum
- based on the slim design very suitable to renew existing lines with high end palletising performance
- advanced servo technology for best motion performance
- global and uniform product support

[WWW.FANUC.EU](http://WWW.FANUC.EU)

# M-410iC/110



Max. load capacity  
at wrist: **110 kg**



Max. reach:  
**2403 mm**

Controlled axes	Repeatability (mm)	Mechanical weight (kg)	Motion range [°]						Maximum speed [°/s]				J4 Moment/Inertia (Nm/kgm <sup>2</sup> )	J5 Moment/Inertia (Nm/kgm <sup>2</sup> )	J6 Moment/Inertia (Nm/kgm <sup>2</sup> )		
			J1	J2	J3	J4	J5	J6	J1	J2	J3	J4				J5	J6
4	± 0.05	1030	370	125	140	720	-	-	145	130	140	420	-	-	53	-	-



## Robot

Robot footprint [mm]	<b>M-410iC/110</b> 761 x 610
Mounting position Floor	•
Mounting position Upside down	-
Mounting position Angle	-

## Controller

Open air cabinet	-
Mate cabinet	-
A-cabinet	•
B-cabinet	○
iPendant Touch	•

## Electrical connections

Voltage 50/60Hz 3phase [V]	380-575
Voltage 50/60Hz 1phase [V]	-
Average power consumption [kW]	3

## Integrated services

Integrated signals on upper arm In/Out	8/8
Integrated air supply	2

## Environment

Acoustic noise level [dB]	75.3
Ambient temperature [°C]	0-45

## Protection

Body standard/optional	IP54
Wrist & J3 arm standard/optional	IP54

## Load Capacity

Max. load capacity at J2 base [Kg]	550
Max. load capacity at J3 arm [Kg] *	30

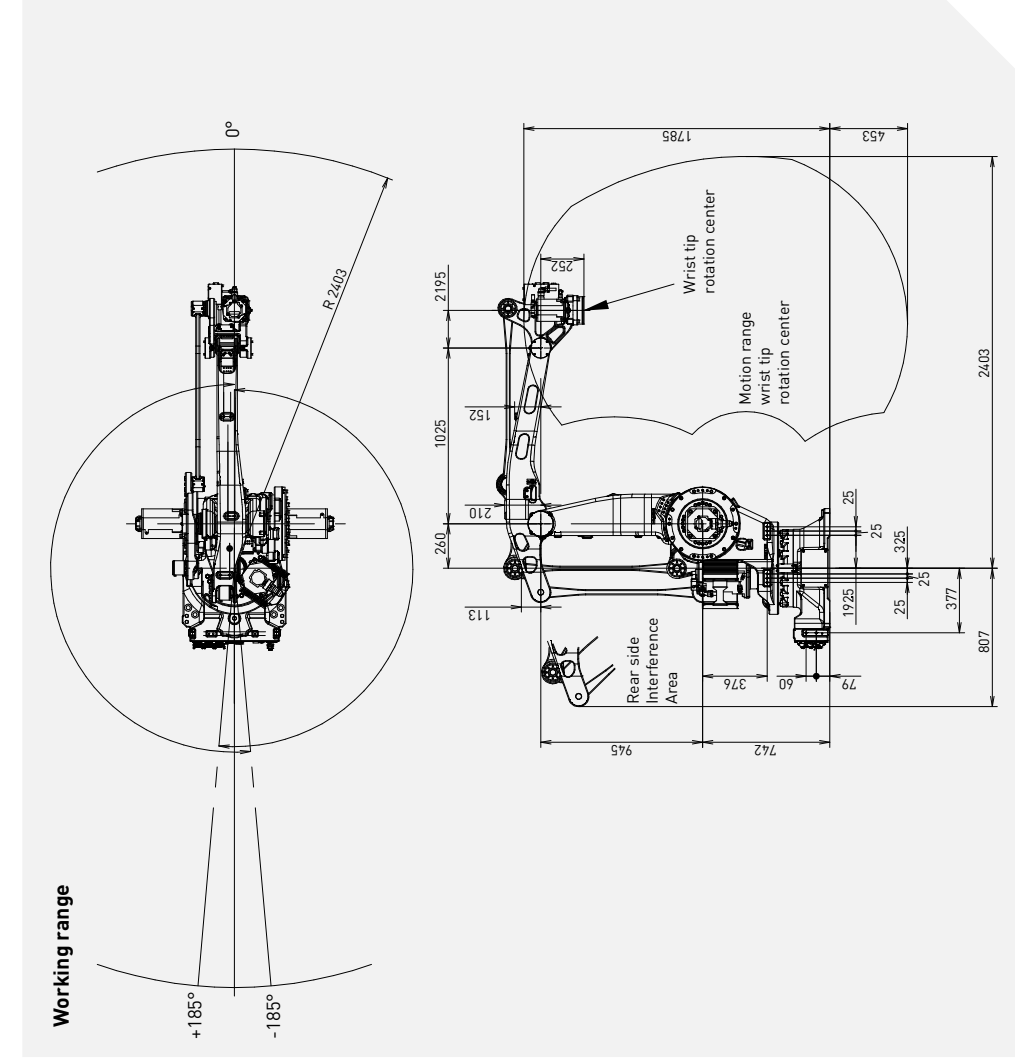

• standard ○ on request - not available ( ) with hardware and/or software option  
\* payload capacity change when arm load is used